



TRANSPORTATION

**ON-BOARD TRAIN
INTERCONNECTION SYSTEM**

TecniKabel

SPECIAL ELECTRICAL AND OPTICAL CABLES

WWW.TECNIKABEL.COM

tecniKabel

SPECIAL ELECTRICAL AND OPTICAL CABLES

TECNIKABEL is focused on constant product innovation to get competitive advantages with endless commitment to research and development.

PRODUCTION

Updated production Systems, stringent process procedures and expert operators reached the goal to carry out our production efficient and flexible. In 30 years of activity, we produced more than 26.000 different types of cables.

FINAL INSPECTIONS

At the end of production processes each cable is checked in its electrical optical and physical performances for a complete compliance to customer specifications.











LABORATORY TESTS

We submit our cables to the most severe tests, simulating critical applications. In addition to the classic tests required by current rules, we made special equipments for different types of mechanical, environmental, electric and optical tests.

MATERIALS RESEARCH AND DEVELOPMENT

Our thirty year experience took us to carry on research of new materials in order to improve performances, costs and fulfil the standards required by our customers.

PRODUCT LINES

	TRANSPORTATION
	OIL / GAS & PETROCHEMICALS
	TELECOMMUNICATION
	OPTICAL
	AUTOMATION
	BUILDING TECHNOLOGY
	SUBMARINE
	AUDIOVIDEO
	NAVAL
	GREEN ENERGY



QUALITY SYSTEM

Since 1978, constant commitment to Quality has awarded Teknikabel approval from American and European Authorities, complying with the most demanding international manufacturing and quality standards.





ON-BOARD MODULAR TRAIN INTERCONNECTION SYSTEM FOR DATA TRANSMISSION

This document covers the background to Teknikabel's development of a new family of interconnection products (cables, connectors and harnesses) specifically designed for on-board train communication infrastructure.

Information, entertainment and security are key aspects to improve train passenger satisfaction. Service availability is based on data and signal transmission between train carriages and between the train and ground stations. The intense data traffic behind these applications requires an adequate communication infrastructure whose characteristics are crucial to allow future-proof and hassle-free operations. High performance in terms of speed and reliability are already a clear need for current services but they become more important still when looking to future developments. On-board, the transmission infrastructure is normally done with wired connections which, like a vertebrate spine, extends into the carriages and connects them to one other. A network of this type can provide support to, for example, the PIS system

(Passenger Information System), video surveillance systems, monitoring and maintenance systems, fire alarm systems, fault reporting, etc. The peculiarity of the mobile railway environment and the need to continuously improve performance are motivating factors driving dedicated and specific product development.

Tecnikabel's goal has been to create a complete line of solutions not limited to a range of cables but covering the entire on-board network wiring (Ethernet and data), and also providing complete harnesses. These are specific products for transmission infrastructure inside carriages and from carriage to carriage. Emphasis has been placed on achieving reliable high-quality products to provide cutting-edge future-proof solutions. Parts flexibility has also been given careful thought, leading to modular cables and harnesses that can be easily adapted to the varying needs of customers. With sector regulations in mind, we aimed to develop "global" products, i.e. products able to comply comfortably with different national, international or proprietary standards.

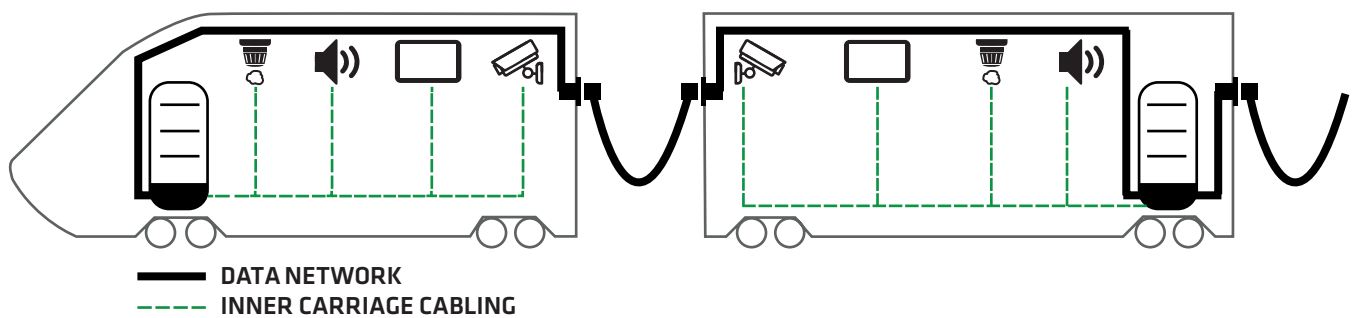

On-board train data network scheme

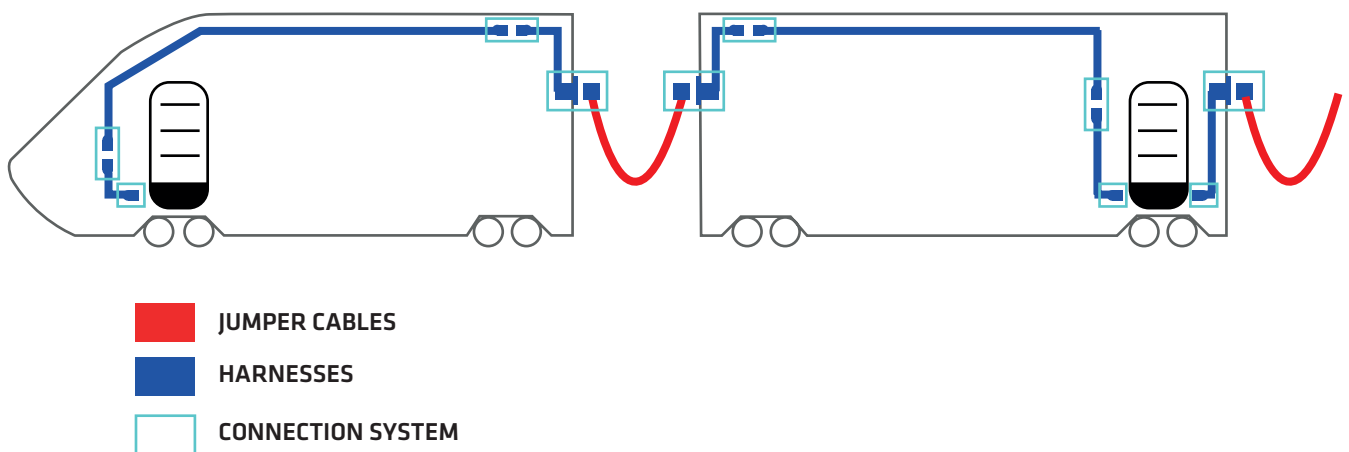

Tecnikabel product family



Examples of Tecnikabel harnesses

This document focuses on some innovative elements of this new product line:

1

JUMPER CABLES and, in particular, those for Ethernet and high-speed data transmission (up to Cat. 7A and data line with MVB, WTB, RS485, UIC 18 poles)

2

modular **CONNECTION SYSTEMS** and connectors for Jumpers

3

the complete **HARNESSES** for on-board network infrastructure, inside carriages and from one carriage to another

4

VALIDATION of the entire wiring system, through standards compliance, specific stress tests and accelerated aging tests (train simulator)

JUMPER CABLES

A railway jumper cable is external wiring that connects two adjacent carriages of a train and is inevitably subject to particularly severe and specific conditions of use. The jumper undergoes continuous mechanical stress caused by the acceleration, vibration and relative motion of adjacent carriages. It must operate in extreme climatic conditions in a broad range of temperatures, from torrid heat to the presence of rain, snow and ice. Aggressive chemicals like lubricating oils and grease from different train parts, can come into contact with a jumper so it must be sufficiently resistant to survive these environments. Lastly, it must meet strict safety requirements governing ignitability, flame spread and the amount of heat, smoke and toxic fumes produced (EN 45545).



CAT 7A cable

Our development started with the study of plastic compounds to be used in the coating sheath. More than other cable parts, the outer sheath influences cable behaviour at different temperatures, its resistance to chemical agents, and the fire behaviour of the finished cable. Tecnikabel coordinated a two-year research project on plastic material composition, additives and production processes for cable sheaths. Co-funded with European funds, and involving research institutions (Turin Polytechnic and Turin University) and industrial partners, the project achieved a jumper cable with optimal characteristics and behaviour. Various traditional plastics and mineral fillers normally used in the sector were screened, and additions of nano-compound fillers helped expand the operating ranges, while maintaining the flexibility and resistance so indispensable to the cable's use. This gave us the necessary formulations to overcome the strict tests required by international standards so as to guarantee the optimal performance and lifespan of our jumper cable.

In terms of transmission, we focused on a four twisted pair cable, suitable for data transmission, that complies with the most advanced international standards and offers the features of a Cat 7A. This is characterized by:

- A 1000 MHz transmission band (ISO / IEC 11801 Class FA standard) capable of comfortably supporting 10 Gb/s Ethernet protocol over distances of 100 m (IEEE 802.3ae, 10GBASE-T).
- 23 AWG copper wire to improve attenuation.
- Individually shielded pairs with aluminium tape.
- Total screen with tinned copper braid.

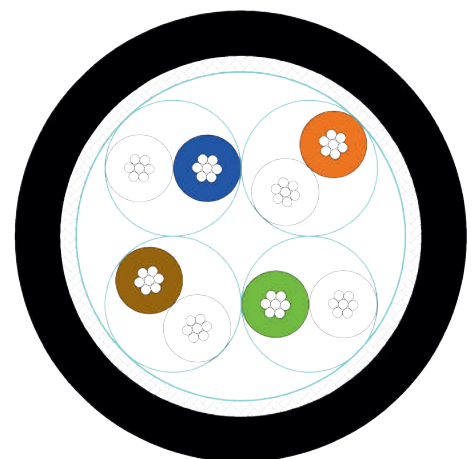

CAT 7A cable cross-sectional view

ETHERNET CABLE 4 PAIRS 23 AWG CAT.7A FOR JUMPER RAILWAY APPLICATION

ELECTRICAL CHARACTERISTICS

Test Voltage	1 kVd.c. or 0,7 kVa.c. for 1 minute
Operating voltage	125 V
Resistance of the conductor at 20°C	≤ 69,5 Ω/km
Insulation Resistance at 20°C	≥ 5000 MΩxkm
Nominal Capacitance at 800 ÷ 1000 Hz	43 pF/m
Average Characteristic Impedance	100 ± 10 Ω at 100MHz
Velocity of propagation	78 %
Transfer Impedance at 1 MHz	≤ 10 mΩ/m
10 MHz	≤ 10 mΩ/m
30 MHz	≤ 30 mΩ/m
100 MHz	≤ 100 mΩ/m

OTHER CHARACTERISTICS

Standard Reference DIN 5510, UNI 11170, UNI EN 45545, IEC 61156-6

Temperature Range	-40°C + 90°C
Bending Radius	7 x D
Net weight	105 Kg/km
Flame propagation (one vertical cable)	EN 60332-1-2
Flame propagation (bunched cable)	EN 50305 par.9.1 (EN 50266-2-5)
Low Smoke density	EN 61034-2 Transmittance ≥ 70%
Degree of acidity of gases evolved during of the combustion	EN 50267-2-2 pH ≥ 4,3 Conductivity ≤ 10μS/mm
Halogen acid gas emission	EN 50267-2-1 HCL ≤ 0,5 %
Fluorine content	EN 60684 -2 ≤ 0,10%
No Toxic Gases	EN 50305 par.9.2 ≤ 3

TRASMISSION CHARACTERISTICS according to IEC 61156-6

Attenuation

Frequenzy	MHz	1	4	10	16	20	62.5	100	200	300	600	800	1000
Required	dB/100m	3.01	5.38	8.71	11.0	12.29	21.85	27.78	39.70	49.03	70.65	82.38	92.89

Near-End Crosstalk (NEXT)

Frequenzy	MHz	1	4	10	16	20	62.5	100	200	300	600	800	1000
Required	dB/100m	78	78	78	78	78	78	78	73.88	71.24	66.73	64.85	63.40

Power-Sum Near-End Crosstalk (PSNEXT)

Frequenzy	MHz	1	4	10	16	20	62.5	100	200	300	600	800	1000
Required	dB/100m	75	75	75	75	75	75	75	70.88	68.24	63.73	61.85	60.40

Return Loss

Frequenzy	MHz	1	4	10	16	20	62.5	100	200	300	600	800	1000
Required	dB/100m	20	23.1	25	25	25	20.74	18.99	16.4	15.6	15.6	15.6	15.6

The objective was to achieve a cable with performances superior to the reference standard and with a very high noise immunity, making it particularly suitable for use on-board trains.

With this in mind, strict control over materials and production processes is of primary importance. Small deviations in materials and process parameters may cause unacceptable transmission behaviour degradation. In particular, the centering and uniformity of insulation thicknesses used on individual conductors, the constancy and regularity of a pair's stranding pitch, and screen tape and braid quality, are among the key elements in assuring high quality Ethernet and data cable production. Thanks to its years of experience in manufacturing data cables Teknikabel introduced state-of-the-art production lines equipped with cutting-edge sensors and accurate process control technologies in order to successfully achieve a high degree of automation in all its key production steps.

Electrical and transmission characterization is fundamental in the development and prototyping stages, in the subsequent validation and qualification process, and, finally, in the production phases. The Teknikabel test labs are equipped with the very latest test equipment, ready to perform all the electrical and transmissive measurements required in order to meet the most recent stringent standards in force.

The same care and attention is paid to the production of the other types of cable required to build a complete on-board transmission infrastructure. Customers can expect the same quality and reliability for cables such as Cat 5E cables or twisted pair cables for MVB (Multifunction Vehicle Bus), WTB (Wire Train Bus) or RS-485.

The availability of a huge selection of cable types allow us to find flexible solutions for specific customer requests.



Railway cables for on-board transmission infrastructure

2

THE CONNECTION SYSTEM

On top of good cables, you need good connectors to build a network. The jumper cable connection system, as already illustrated, must withstand very hard operating conditions. It is therefore an essential element that needs to be studied, designed and produced specifically for this application. To ensure the right skills were used, Teknikabel worked in partnership with connector manufacturers specializing in the railway sector. The project for a new jumper connection system took into consideration connectors that were already in use. We performed a deep and critical performance analysis on these connectors to identify weaknesses and problems that our new connection system needed to overcome.

The interconnection system for a jumper consists of a “mobile” connector, assembled at the end of the cable and its fixed counterpart, joined to the carriage. Various potential constraints mean it is not always possible to place the fixed part in the most accessible and convenient position. It is therefore often difficult to hook and release these connectors. **The Teknikabel jumper connection system was designed to guarantee an easy and safe connection even in the most problematic situations, thereby guaranteeing:**

EASE, SPEED AND SAFETY OF THE CONNECTION	IMMEDIATE RELEASE	IP67 PROTECTION	QUALITY CONNECTION
connection by using a bayonet mechanism to hook, and locking by rotating a rubber ring a quarter of a turn	Immediate release in the event of an emergency by simply pulling the quick release cord	IP67 protection rating (EN 60529)	Quality connection in all operating conditions



Jumper connector



Modular jumper connection system

Different customer needs and different applications call for the development of modular connection systems. According to the specific use, the connector can be configured using different modules in order to achieve the intended functionality. Modules have been conceived and manufactured as complete connectors that can then be pre-mounted on the appropriate type of cable and tested as a finished part. After passing the control tests, the cabled modules are easily inserted into the appropriate connector housings, using the special guide system that ensures stable, precise and reliable positioning. Connectors can have different capacities, from a minimum of one module to a maximum of seven, depending on configuration needs.

Available modules are:

- 2 x 4 contacts, Cat 6A, Cat 7, Cat 7A
- 2 contacts, WTB
- 4 contacts, Cat 5E, MVB
- 12 contacts, 20 AWG

Combining these modules in the final connector, and choosing the proper cables, gives rise to different jumper harnesses. For example, configurations for WTB (Wire Train Bus) and MVB (Multifunction Vehicle Bus), RS485 and UIC 18 poles are possible.

Various commercial connectors can be used (from Siemon's TERA to the more common RJ45 style) for internal carriage cabling.



CAT 7A modules



7 modules jumper connector

3

HARNESSES

To speed up and facilitate installation and testing of the wired on-board communication infrastructure, Teknikabel can supply complete “ready to go” wiring kits based on customer specifications. Different cable types, lengths, branch points, connectors and components can be requested. Internal carriage or external jumper cables can be supplied. Teknikabel can offer its skill and experience to help you choose and specify all parts of the network. Assembly and testing operations are carried out in a fully-equipped dedicated plant where skilled people transform customer drawings into fully functional pieces ready to be installed. All components are 100% tested as subassembly and as complete harness or network. The actual installation on-board the train is completely reproduced connecting the proper harnesses and by carrying out all the tests and measures envisaged. This process terminates with a full detailed report and identity card of the wiring. Teknikabel approach guarantees the customer the highest possible quality and performance, reduces installation time and limits the risk of potential issues arising during on site assembly.

All Teknikabel components for modular on-board interconnection systems for data transmission meet the strict standards required and are guaranteed to meet the declared level of performance. A complete final network can only perform in compliance with the required standards if all the parts have been employed properly and installed in a workmanlike manner. Respecting and following all instructions and constraints is crucial in order to successfully build a wired data infrastructure.

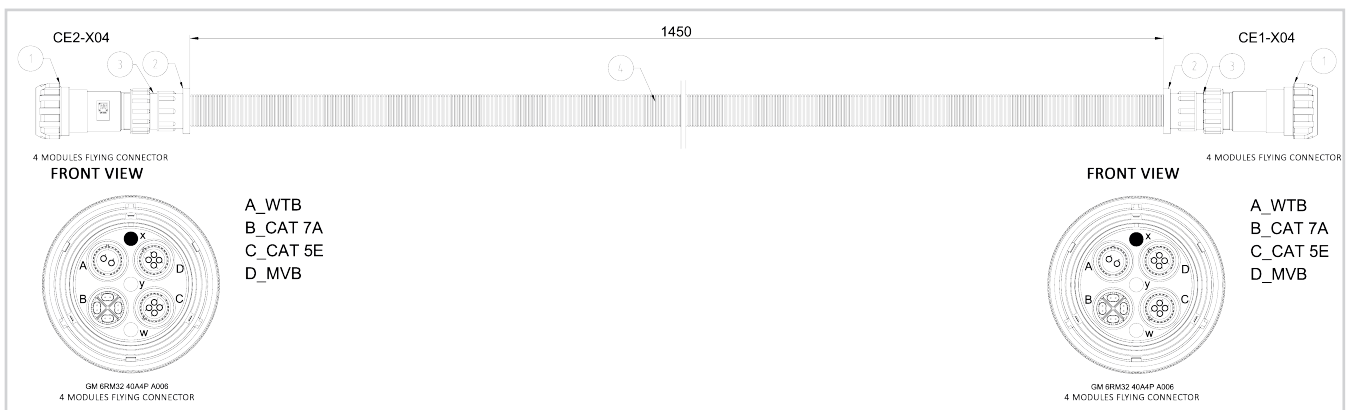

Example of a Jumper drawing



The finished harness - front view



The finished harness - top view

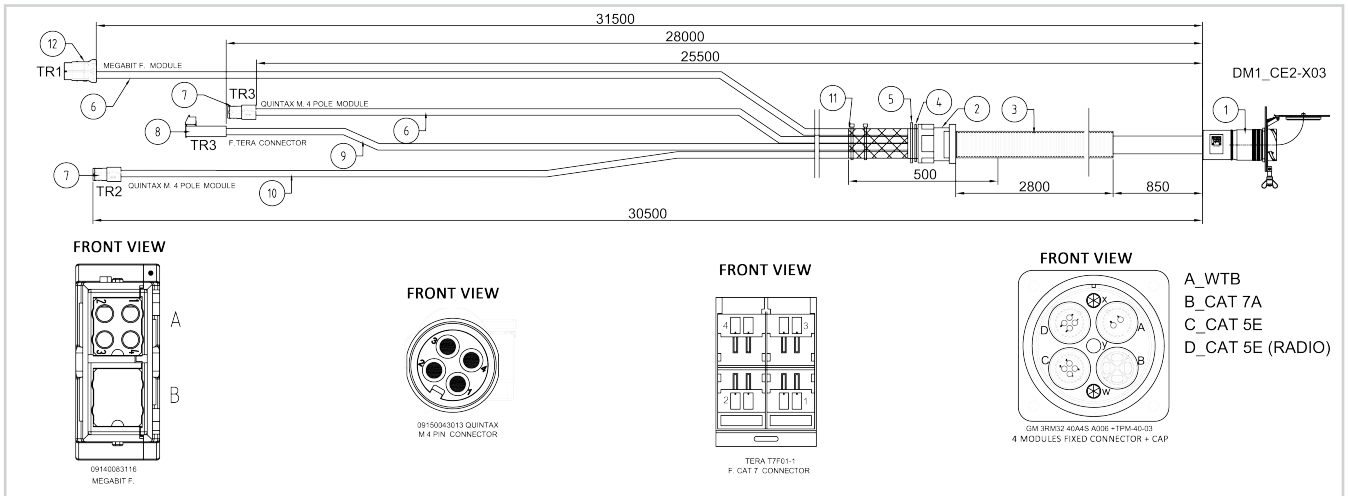

Example of inside carriage harness drawing



The finished harness



The finished harness - connectors detail

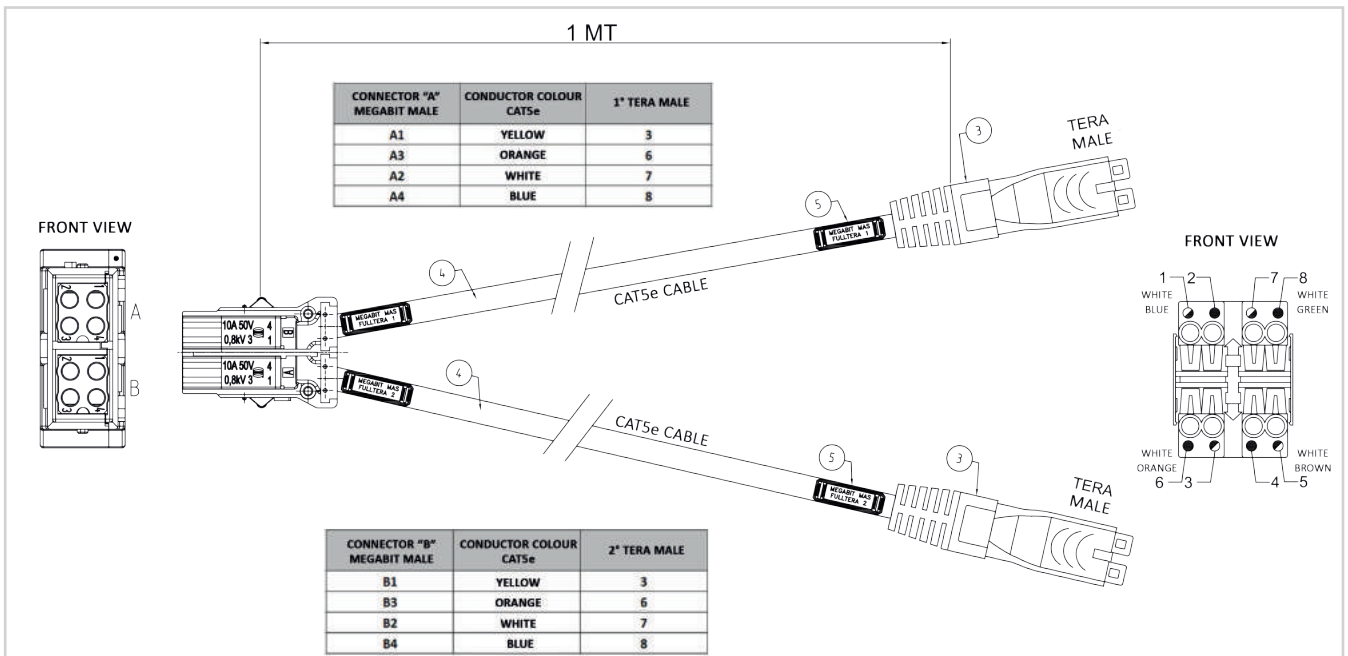

Example of internal carriage cabling drawing

A complete and exhaustive validation of all parts was carried out to check the quality of new products and their compliance with their pre-set standards.

The cables, the interconnection systems and the complete harnesses passed all tests with excellent results and, in particular, all transmission tests were passed by ample margins. Large margins, when set against the values specified in standards, are objective proof of the quality we achieve and increase confidence in a complete and fully-functional assembled network. Accidental and uncontrolled stress conditions (such as traction, bending or crushing) can occur during installation due to difficult installation paths, limited space, etc. These often unavoidable events could jeopardize the final result and performance if you work with materials and products that barely reach compliance with the required standards.

On top of international standards tests, our validation included specific technical tests such as those prescribed in Trenitalia specifications, in addition to further tests specifically studied and defined by Teknikabel.

In the continuous search for product improvement, Teknikabel has designed and built a train mechanical simulator able to reproduce and amplify the mechanical stresses that a jumper undergoes when the train is moving. Carried out in collaboration with railway rolling stock producers and based on careful analysis of the relative movements that develop between two moving carriages, the Teknikabel simulator reproduces movement in a controlled manner, as well as exacerbating and intensifying the stress. The



Complete on-board network harnesses

simulator reproduces the mechanical stresses generated by the relative movement of the carriages along three axes and applies controlled vibrations to the fixing points of the connection system. This simulator can be used, for example, for jumper cable durability and reliability tests. This system can also be placed inside a climatic test chamber. This allows life tests to be carried out even in the most extreme environmental conditions and adds thermal stress to the mechanical stress tests already foreseen. The complete wiring can be operated during the simulator tests in order to monitor the stability or degradation of the entire transmission infrastructure. The transmission bit error rate (BER) can be measured and recorded while simulating the operation in motion at a specified temperature.

Collecting such data has allowed Teknikabel to optimize and improve products specifically developed for implementing on-board transmission networks.



Train simulator

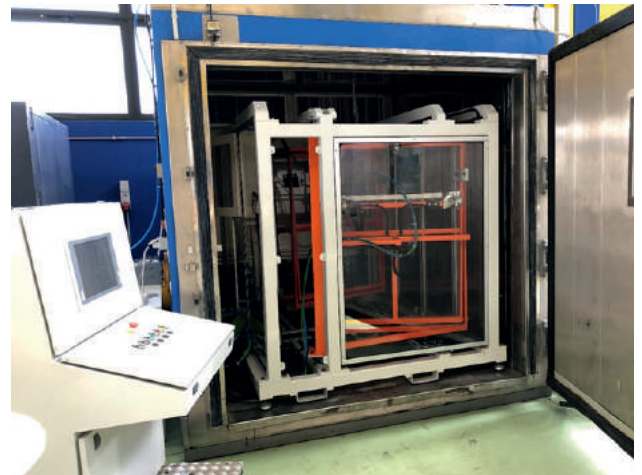

Train simulator inside a climatic chamber



TecniKabel

SPECIAL ELECTRICAL AND OPTICAL CABLES

HEADQUARTER

VOLPIANO
Via Brandizzo, 243
10088 Volpiano (Turin) Italy
Tel. +39 011 9951997
Fax +39 011 9953062
www.tecnikabel.com

PRODUCTION PLANTS

VOLPIANO
Via Brandizzo, 243
10088 Volpiano (Turin) Italy

ALMESE
Via Rivera, 100
10040 Almese (Turin) Italy

PRODUCTION



TK CHINA
Cables & Connectors
Factory Premises Co., Ltd No. 7
111 North Dongting Road
Taicang Economy Development Area
Taicang City, Jiangsu Province, China
Tel. +8617751210891

DISTRIBUTION



TK SERVICE S.R.L.
via Brandizzo, 245
10088 Volpiano - (To) Italy
Tel. +39 011 995 1997
Fax +39 011 995 3062

BRANCH OFFICES



TECNIKABEL ROME
Via Casali delle Cornacchiole, 160
00178 Roma Italy
Tel. +39 06 5099 2552
Fax +39 06 5051 4022



TECNIKABEL ME JLT
3008 Mazaya Business Avenue
Jumeirah Lake Towers
Dubai, UAE
Tel. +9714 4230877



TK DEUTSCHLAND GmbH
Herdewerg 8
83623 Steingau, GERMANY
Tel. +49 9421 9744222



TECNIKABEL ASIA PTE LTD
11 Tuas Cres
SINGAPORE 638705
Tel. +65 6909 3710

TecniKabel

SPECIAL ELECTRICAL AND OPTICAL CABLES

WWW.TECNIKABEL.COM